

# RTS23FD

## Hardware Kit Includes Loose:

- (1) 8 – Hex head bolts (M8-1.25 x 30mm) Grade 8
- (2) 20 – Lock washers (M8) Grade 8
- (3) 28 – Flat washers (M8) Grade 8
- (4) 20 – Hex head nuts (M8-1.25) Grade 8

## Components List:

- (1) 2 – Heavy Duty RT Steps RTSPN042  
1 Driver/1 Passenger
- (2) 4 – Mounting Brackets RTSPN040  
2 Driver/2 Passenger
- (3) 4 – Rubber Isolator (RTSPN044)
- (4) 4 – Rubber Isolator (RTSPN045)

**LOOSE FIT ALL COMPONENTS.  
DO NOT TIGHTEN UNTIL ALL  
COMPONENTS ARE INSTALLED  
AND ADJUSTED.**

**DISCLAIMER: USE ONLY  
COMPONENTS AND HARDWARE  
SUPPLIED BY ICI.  
NO SUBSTITUTIONS.**



# 2015 Ford F150 Ext Cab RTS23FD Installation Instructions

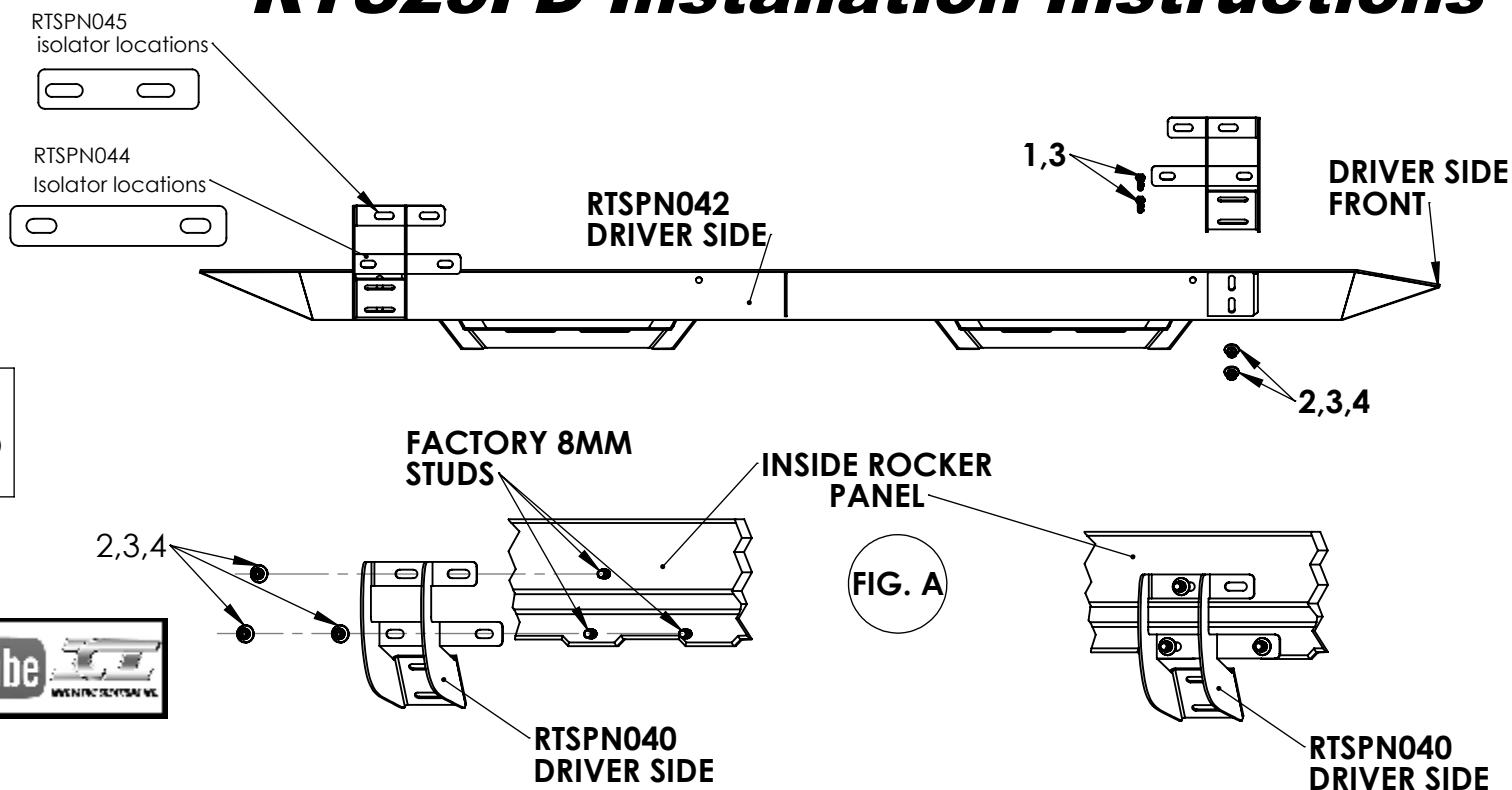

## Step by Step Installation Instructions

- STEP 1:** Read and understand instructions completely before beginning installation.
- STEP 2:** Remove all old steps and hardware from truck.
- STEP 3:** Locate the driver's side step (the front of the step bar has a bend down and a notch on the inside top).
- STEP 4:** On the inside rocker panel there are two mounting points, each with (3) 8mm threaded studs coming out of the panel. Hang RTSPN040 mounting brackets from each of these two mounting points, aligning the studs with the mounting holes in each RTSPN040 bracket (FIG. A). Use provided 8mm nut, lock washer and flat washer for each stud. Use one (RTSPN045) Isolator in between brackets and body (Top holes) and one (RTSPN044) on bottom locations on all four brackets. The factory studs may be covered in paint and need to be cleaned before the 8mm nut will install. Be careful not to cross thread the nut on the studs. Do not tighten mounting brackets to truck until step is attached to mounting brackets and properly aligned.
- STEP 5:** Once RTSPN040 brackets are loose fit to the truck, attach step bar to brackets using supplied 8mm bolts, flat washers, lock washers and nuts. Do not tighten bar to brackets, leave finger tight. Once bar is loose fit to brackets, adjust brackets and tighten brackets to inside rocker of truck. **DO NOT USE IMPACT TOOLS.**
- STEP 6:** Next, adjust bar up/down and front/back then tighten step to brackets. **DO NOT USE IMPACT TOOLS.** Repeat for passenger side.